



921 Corporate Way, Fremont, CA 94539
Tel: +1-510 490-8024 Fax: +1-510-623-7268
Web: <http://www.actisys.com> E-mail: irda-info@actisys.com

ACT-IR8250P

IrDA[®] Compliant Protocol Processor Specification

**January 17, 2007
Version 0.5**

**© Copyright 2003-2007 ACTiSYS Corporation,
All Rights Reserved**

TABLE OF CONTENTS

REVISION HISTORY.....	3
1. FEATURES.....	4
2. OVERVIEW	6
3. PIN DESCRIPTION.....	7
4. CONNECT ACT-IR8250P TO A HOST DEVICE WITH RS232 PORT	8
5. ACT-IR8250P EVALUATION KIT (ACT-IR8250PEK AND ACT-IR8250PEKK)	9
5.1. ACT-IR8250PEK PCB Photos And Dimensions:	10
5.2. ACT-IR8250PEK Circuit Schematics:	12
6. CHARACTERISTICS AND SPECIFICATION	14
6.1. Absolute maximum ratings ☆	14
6.2. Recommended operating conditions:	14
7. PACKAGE DIMENSIONS	16
7.1. SOP28.....	16
7.2. TSSOP28	17
APPENDIX 1. HOW TO USE ACT-IR8250PEK (ACT-IR8250P EVALUATION KIT)	18
8. WARRANTY INFORMATION	20
9. CONTACT INFORMATION	21

REVISION HISTORY

Revision History		
Revision	Date	Comment
0.1	08/21/2003	Preliminary Design Specification
0.2	08/26/2003	Removed Chapter 5 and added Appendix 1
0.3	12/08/2003	Updated reference circuit & IrDA transceiver model #. Updated implementation examples. Added Eval. Kit PCB dimensions and circuit schematics.
0.31	12/19/2003	Updated reference circuit in more detail.
0.4	01/12/2004	Revised Appendix 1 for Development Kit.
0.41	03/31/2004	Revised IR8250SW statement in Appendix 1.
0.42	04/23/2004	Added In-system programming in chapter 9.
0.43	11/22/2004	Added connector of DB dimension on section 10.1.
0.44	01/28/2005	Added IR8250PEK-J1 connector detail on Chapter 10 & 12
0.45	01/17/2007	Change document name to Technical Spec
0.5	01/17/2007	Extracted technical data

ACTiSYS reserves the right to make changes without further notice to any products herein to improve reliability, function or design. ACTiSYS does not assume any liability arising out of the application or use of any product or circuit described herein.

All trademarks, logos, organizations or company names and product model names are the properties of the respective organizations or companies.

1. FEATURES

- A complete IrDA[®] Protocol stack in a single chip, includes mandatory protocols (IrPHY[™], IrLAP[™], IrLMP[™]) and optional protocols (IrLPT[™], IrCOMM[™]+TinyTP[™], OBEX[™] transport or TinyTP with customized IAS class name for IrSocket[™]).
- Also Includes IrPHY encoding/decoding, and interfaces directly to Infrared transceivers for data rate from 9.6kbps up to 115.2kbit/s. Only an external Infrared transceiver is needed to complete an IrDA compliant infrared communication subsystem.
- ACT-IR8250P supports IrDA Secondary mode only.
- Supports 64 bytes data packet for IrDA IrLAP frame.
- Interfaces to Host device via a full function UART port.
- Supports host baud rate from 300k bps to 115.2k bps selecting by programmable settings.
- Programmable Device name, IAS class name and data format setting.
- Available in programmed and tested chip (ACT-IR8250P), assembled & tested board (ACT-IR8250PDB), or assembled & tested evaluation kit (ACT-IR8250PEK).
- Low supply voltage, 3.0 V to 3.6 V.
- Low current consumption; 2 μ A standby, 3mA active.
- Small low profile plastic 28-pin SSOP/TSSOP package.
- In-system-programmable FLASH, facilitates firmware changes or updates.
- The evaluation kit (ACT-IR8250PEK) includes AC power supply, RS232 level translators, and PC software for in-system re-programming of firmware and future firmware options.
- ACT-IR8250PEK consists of: ACT-IR82x0PMB (motherboard) + ACT-IR8250PDB + Self-downloadable SW to program ACT-IR8250P firmware.
 - 1) ACT-IR82x0PMB: RS232 level converter, DB9 connector, probe pins and ACT-IR8250PDB connector.
 - 2) ACT-IR8250PDB (daughter board for direct connection to your embedded PCB):
Self-contained full-function IrDA module, which consists of: ACT-IR8250P protocol IC + IrDA transceiver + 3.3V interface connector.
- A very useful “Evaluation Kit Full Set” is ACT-IR8250PEKK, which is: ACT-IR8250PEK + ACT-IR4000US (notebook/desktop USB-IrDA adapter). This kit set can test ACT-IR8250P (connected to your device), to exchange IrDA data with ACT-IR4000US (connected to PC USB port), running hyper-terminal under Windows IrDA driver. To avoid debugging multiple issues: e.g., Is this a PDA application issue (IrDA SW activated and behaves properly, with the matching protocol layer? ACT-IR8250P to host interface issues (UART data rates, flow control, data bit/parity/stop bit, UART signal pins, power levels)? Performance issues (throughput, distance, error rate/dropping bits)?

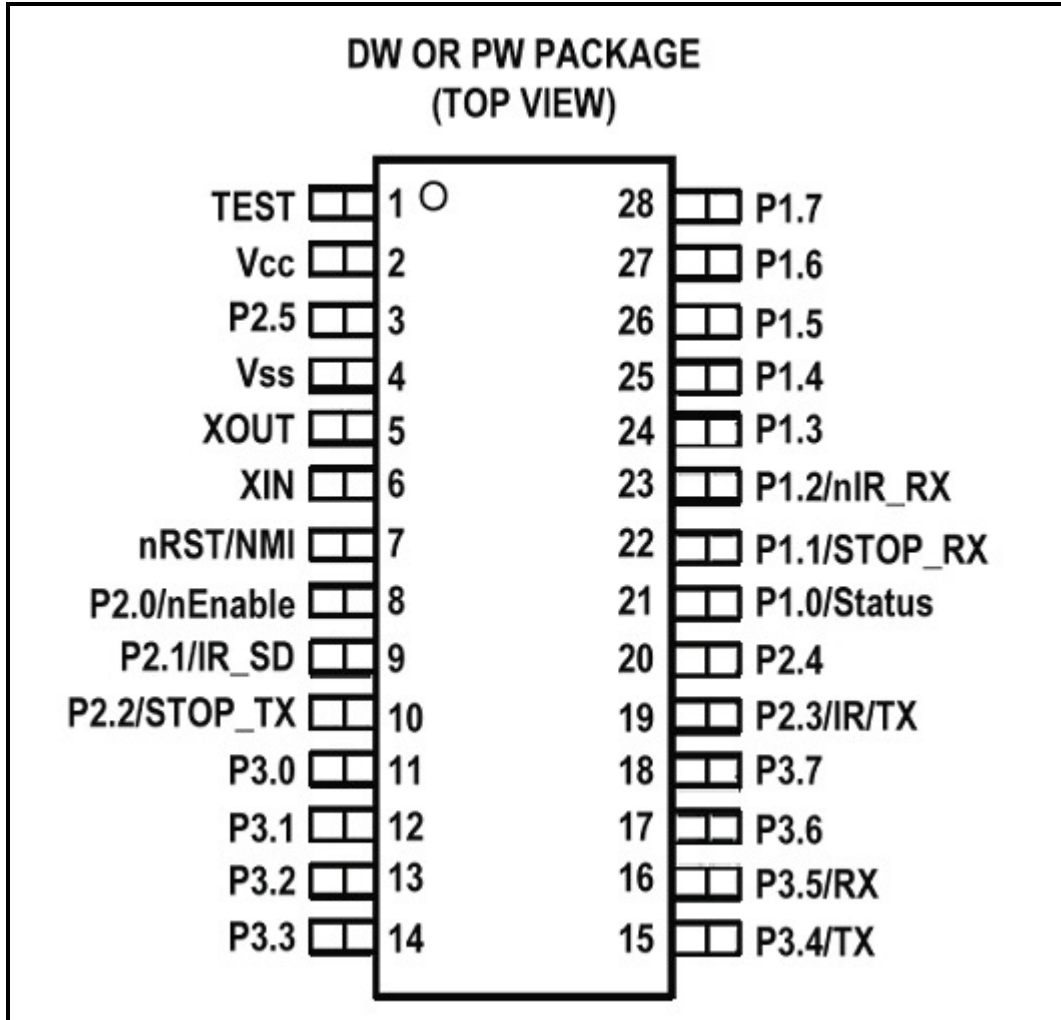

ACT-IR8250P

2. OVERVIEW

ACT-IR8250P is a low cost, small pin-count, high-integration and in-system-programmable micro-controller, with on-chip IrDA protocol stack and on-chip Infrared physical encoder/decoder. It provides a serial interface to a host device that intends to have Infrared communication capability. The host device can be any equipment or device that needs to communicate with IrDA enabled devices via IrDA protocol with only a wired serial interface. ACT-IR8250P will handle all the detail about IrDA protocol. It sends/receives user data to/from the host device via the wired serial interface with hardware flow-control.

IrDA has two modes; one is Primary, and the other is Secondary. The difference between them is that Primary initiates the discovery, negotiation and connection sequence to Secondary, and decides IrDA protocol parameters. While Secondary always passively waits for commands from Primary. Both modes can run different protocols, and both may send or receive user data.

ACT-IR8250P supports Secondary mode only. Fig.1 is system diagram.

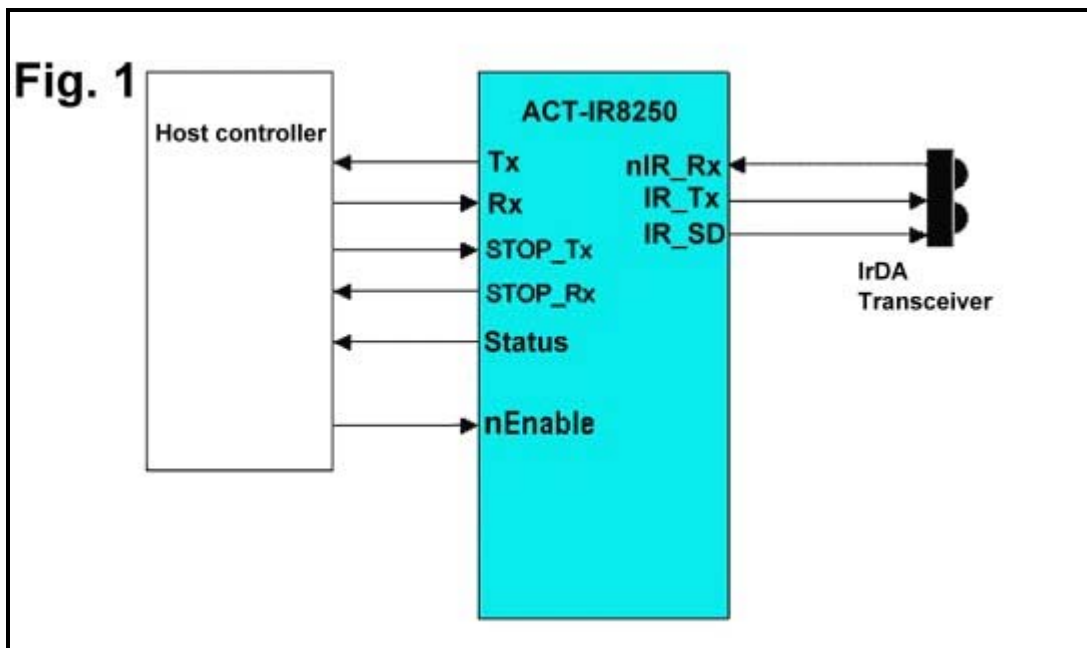

3. PIN DESCRIPTION

Symbol	Pin No.	I/O Type	Descriptions
TEST	1	I	Reserved. Pull low with 30k ohm resistor.
VCC	2	Pwr	Digital supply voltage, positive terminal.
P2.5	3	I/O	Reserved. Pull high with 30k ohm resistor.
VSS	4		Digital supply voltage, negative terminal. Ground,
XOUT	5	I/O	Output terminal of crystal oscillator.
XIN	6	I	Input port for crystal oscillator. Standard crystals can be connected.
n RST/NMI	7	I	Reset input. (n : Active low)
P2.0/ n Enable	8	I	Power control from Host. (n : Active low) High=Power down ACT-IR8250P, Low=Enable and power on.
P2.1/IR_SD	9	O	Shut down transceiver. High=Shut down, Low=Enable.
P2.2/STOP_TX	10	I	TX flow control from host. High=Host not ready to accept TX, Low=Host ready to accept TX.
P3.0 ~ P3.3	11 ~ 14	I/O	Reserved. Keep it open.
P3.4/TX	15	O	Serial data to Host. High=Idle / Stop bit / 1-bit. Low=Start bit / 0-bit.
P3.5/RX	16	I	Serial data from Host. High=Idle / Stop bit / 1-bit. Low=Start bit / 0-bit.
P3.6 ~ P3.7	17 ~ 18	I/O	Reserved. Keep it open.
P2.3/IR_TX	19	O	Transmit data to transceiver. High= IR on, Low=IR off.
P2.4	20	I/O	Reserved. Keep it open.
P1.0/Status	21	O	IrDA status to Host. High=No IrDA connection. Low=IrDA connection active.
P1.1/STOP_RX	22	O	RX flow control to Host. High=ACT-IR8250P not ready to accept RX, Low=ACT-IR8250P ready to accept RX.
P1.2/ n IR_RX	23	I	Received data from transceiver. (n : Active low) High=No IR, Low=IR detected.
P1.3 ~ P1.7	24 ~ 28	I/O	Reserved. Keep it open.

4. CONNECT ACT-IR8250P TO A HOST DEVICE WITH RS232 PORT

Devices that use serial cables for their communication are split into two categories. These are DCE (Data Communications Equipment) and DTE (Data Terminal Equipment.) Data Communications Equipment is the device such as your modem, TA adapter, plotter etc while Data Terminal Equipment is your Computer or Terminal. The following shows how to connect ACT-IR8250P to a DTE and a DCE. Note: A RS232 level converter chip is needed when ACT-IR8250P is connected to a RS232 interface.

There are a total of 7 signals between the host and ACT-IR8250P. The pin assignment and name of each signal at the chip levels are summarized in Table 1 below. Please note that DTE denotes signals on the RS232 board or device. In order to connect them to another DTE, a null-modem converter is used in-between. The pin assignments and the names are listed in this table.

Table : Host interface signals

ACT-IR8250P			RS232 DTE device			RS232 DCE device		
Pin No.	Type	Name	Pin No.	Type	Name	Pin No.	Type	Name
15	O	TX	2	I	RX	3	I	RX
16	I	RX	3	O	TX	2	O	TX
8	I	nEnable	4	O	DTR	6	O	DSR
21	O	Status	6	I	DSR	4	I	DTR
10	I	STOP_TX	7	O	RTS	8	O	CTS
22	O	STOP_RX	8	I	CTS	7	I	RTS
4		GND	5		GND	5		GND

5. ACT-IR8250P EVALUATION KIT (ACT-IR8250PEK AND ACT-IR8250PEKK)

It is recommended that customer verify the compatibility with your host system by using ACT-IR8250P evaluation kit, ACT-IR8250PEK. It is a self-contained unit, with ACT-IR8250P, IrDA transceiver, RS232-level converter and external AC power connector. All built into a compact package. ACT-IR8250 evaluation kit immediately enables your host system to be IrDA (IrReady) certifiable. Moreover, this kit can be a full PCB with RS232 interface, or as half-PCB with UART interface, without the burden of RS232 interface circuitry.

ACT-IR8250PEK package consists of:

IR82x0PMB (motherboard) + ACT-IR8250PDB + Self-downloadable SW to program ACT-IR8250P firmware.

- 1) **ACT-IR82x0PMB:** RS232 level converter, DB9 connector, probe pins and ACT-IR8250PDB connector.
- 2) **ACT-IR8250PDB (daughter board for direct connection to your embedded PCB):**
Self-contained full-function IrDA module, which consists of:
ACT-IR8250P protocol IC + IrDA transceiver + 3.3V interface connector.

A more useful Evaluation Kit Full Set is **ACT-IR8250PEKK**, which is: ACT-IR8250PEK + ACT-IR4000US (notebook/ desktop USB-IrDA adapter). This set can test ACT-IR8250P (connected to your device), to exchange IrDA data with ACT-IR4000US (connected to PC USB port), running Hyper-terminal with Windows IrDA driver. It can avoid debugging multiple issues: e.g., Is this a PDA application issue (IrDA SW activated and behaves properly)? Is this an ACT-IR8250P to host interface issue (UART data rates, flow control, data bit/parity/stop bit, signal pins, power levels)? Or is this a performance issue (throughput, distance, error rate/dropping bits)?

The following figure is ACT-IR8250P evaluation kit, ACT-IR8250PEK.

It consists of two boards: ACT-IR82x0PMB on the left, and ACT-IR8250PDB on the right, connected to each other by 10 pin connector/cable. You can connect this evaluation kit to your host RS232 port, or use ACT-IR8250PDB board to connect to your host CMOS level UART signals.

The corresponding circuit schematics for ACT-IR82x0PMB and ACT-IR8250PDB are also included below. The detail User's Guideline is described in Appendix 1. How to use ACT-IR8250PEK.

5.1. ACT-IR8250PEK PCB Photos And Dimensions:

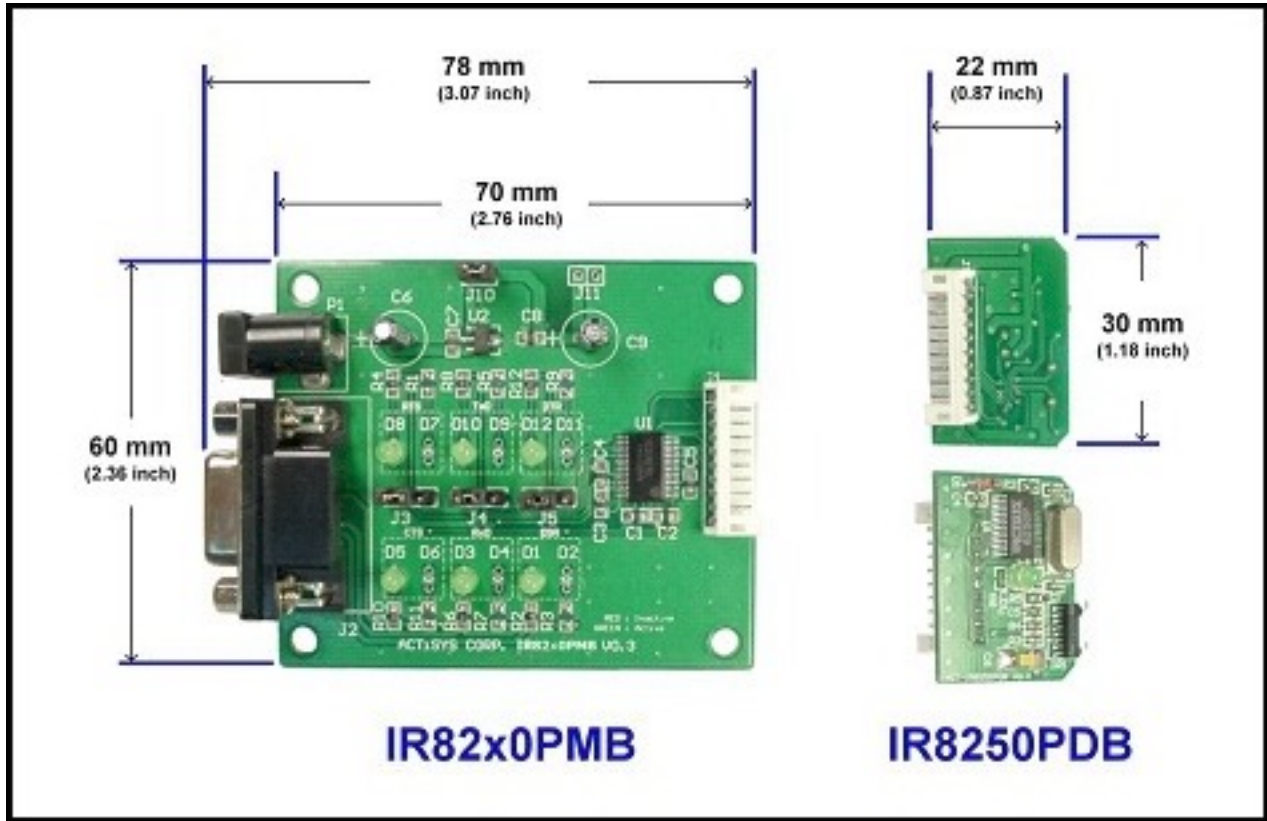

PCB footprint & dimensions, part number, supplier and pinout spec for the connector J1 on IR8250x0PMB and ACT-IR8250PDB boards are as follows: Molex, part number SD-48148. You can get dimensional information at: www.molex.com. More details on the next page.

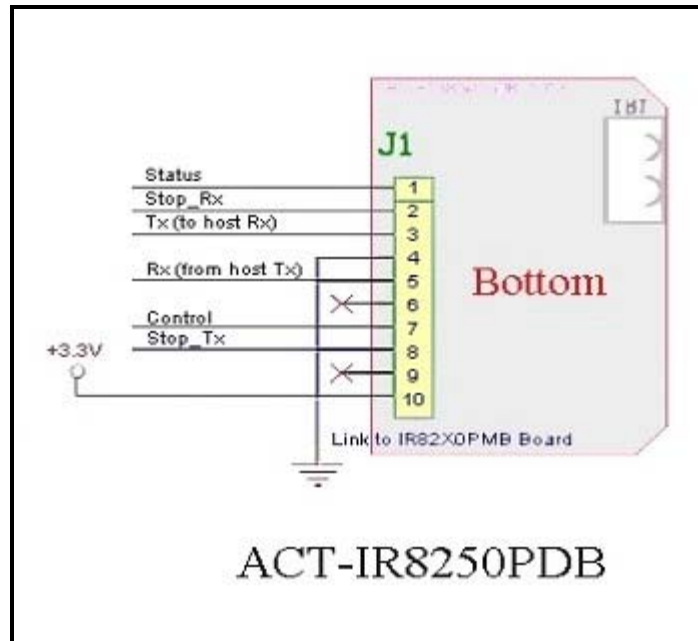

J1 Connector: CONN JST(M) 10Pin

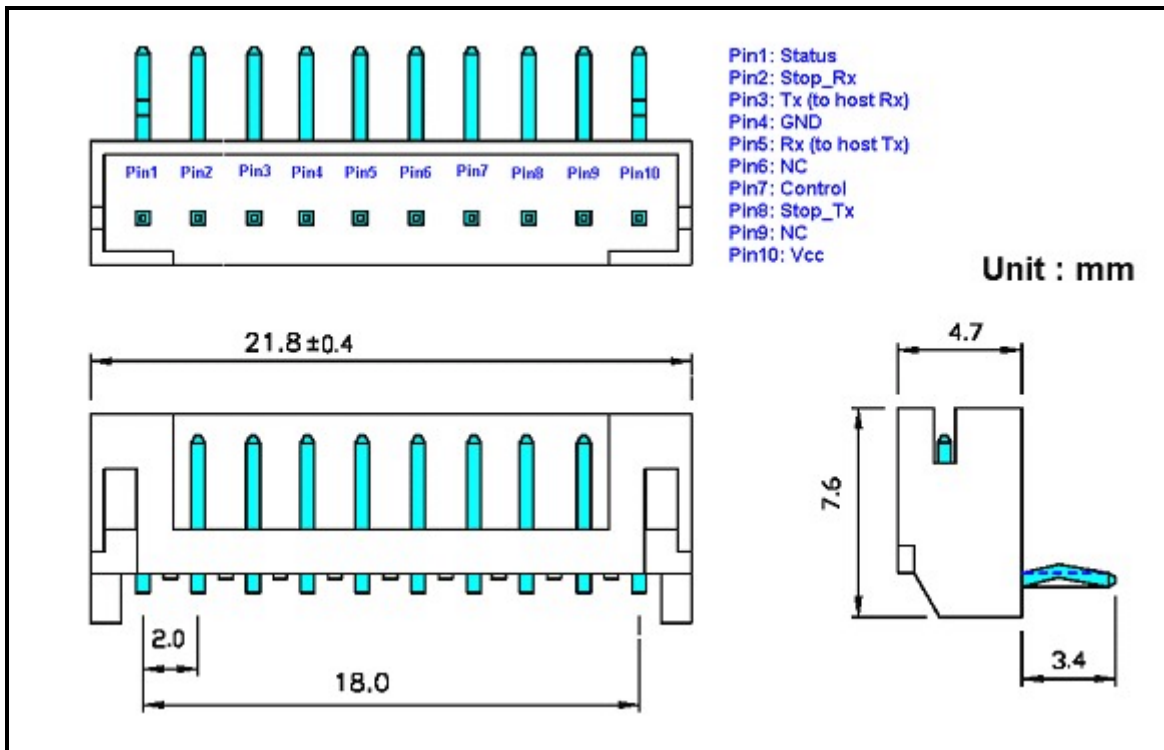

5.2. ACT-IR8250PEK Circuit Schematics:

5.2.1. ACT-IR82x0PMB Motherboard Circuit Schematic:

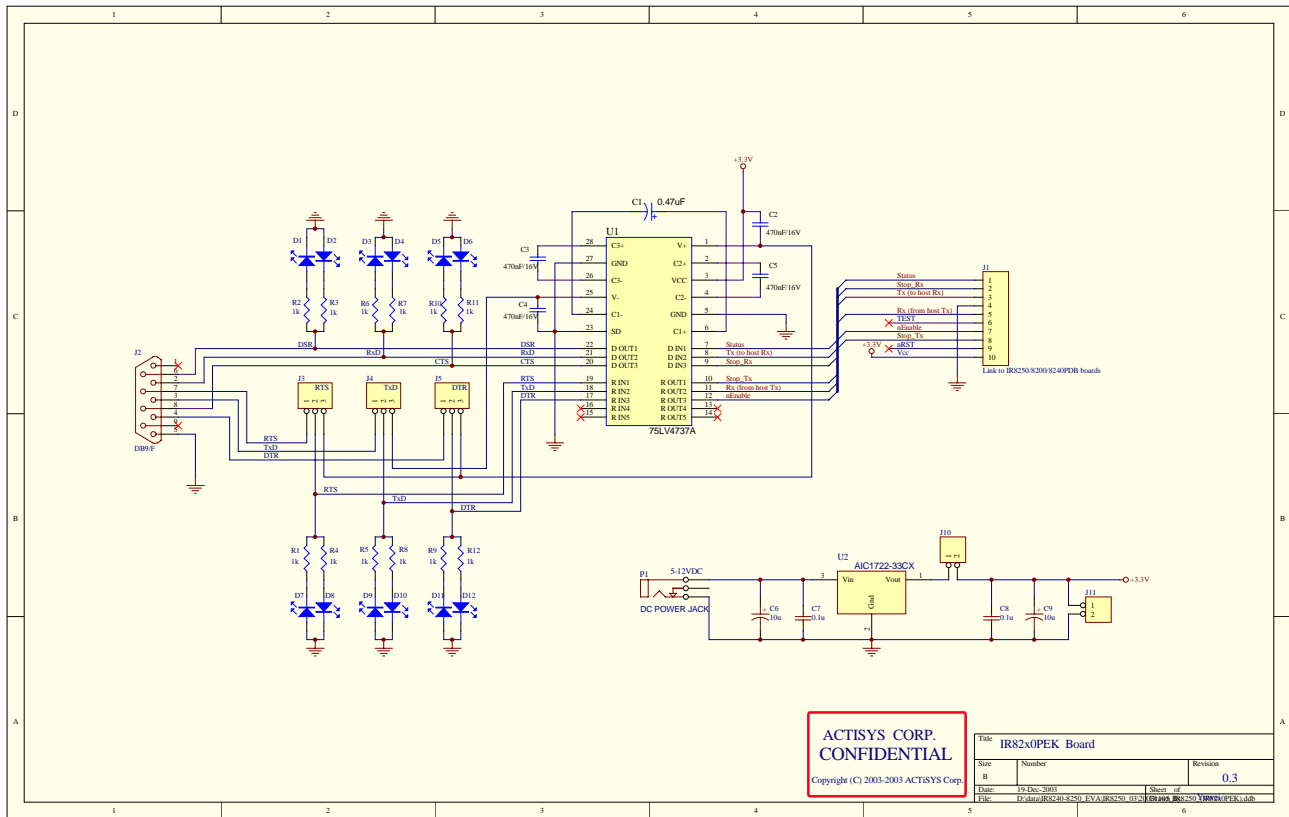

PCB footprint & dimensions, part number, supplier and pinout spec for the connector J1 on ACT-IR8250x0PMB and ACT-IR8250PDB boards are as follows: Molex, part number SD-48148. You can get dimensional information at: www.molex.com. More details on [section 5.1](#).

5.2.2. ACT-IR8250PDB Daughter Board Circuit Schematic

If your design uses daughter board configuration for convenient placement against front panel, with cable connection to your system board, it is advisable to maintain the 10 pin connector as in this reference circuit. This enables in-system ACT-IR8250P firmware re-programming with new firmware if such need arises. This flexibility can extend your product lifetime, improve compatibility with new IrDA devices, add or change IrDA functionality. Indeed it's a valuable and useful feature.

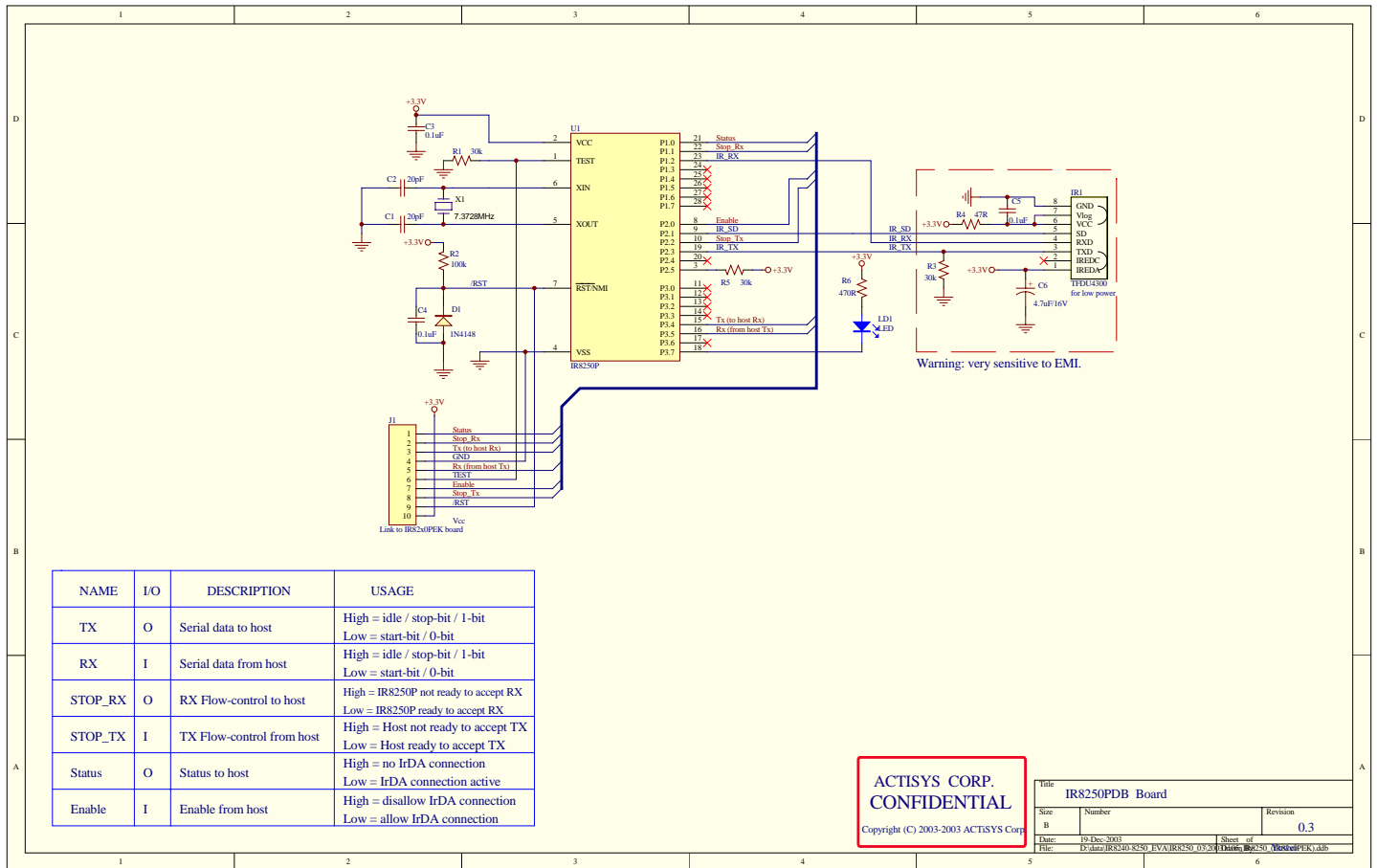

PCB footprint & dimensions, part number, supplier and pinout spec for the connector J1 on ACT-IR8250x0PMB and ACT-IR8250PDB boards are as follows: Molex, part number SD-48148. You can get dimensional information at: www.molex.com. More details on [section 5.1](#).

6. CHARACTERISTICS AND SPECIFICATION

6.1. Absolute maximum ratings ☆

Parameter	Value
Voltage applied at VCC to VSS	-0.3 V to 4.1 V
Voltage applied to any pin (referenced to VSS)	-0.3 V to VCC+0.3 V
Diode current at any device terminal	±2 mA
Storage temperature, Tstg (un-programmed device)	-55°C to 150°C
Storage temperature, Tstg (programmed device)	-40°C to 85°C

☆ Stresses beyond those listed under “absolute maximum ratings” may cause permanent damage to the device. These are stress ratings only, and functional operation of the device at these or any other conditions beyond those indicated under “recommended operating conditions” is not implied. Exposure to absolute-maximum-rated conditions for extended periods may affect device reliability.

NOTE: All voltages referenced to VSS.

6.2. Recommended operating conditions:

Parameter	MIN.	TYPICAL	MAX.	Units
Supply voltage during program execution, VCC	1.8	3.3	3.6	V
Supply voltage, VSS		0		V
Operating free-air temperature range, TA	-40		85	°C
DC current (Shut down mode)		2		μA
DC current (Active mode)		2		mA
Crystal frequency		7.3728		MHz

The DC current in active mode is not included transceiver operating current.

Electrical characteristics over recommended ranges of supply voltage and operating free-air temperature (unless otherwise noted)

Schmitt-trigger inputs Port P1 to Port P3; P1.0 to P1.7, P2.0 to P2.5, P3.0 to P3.7

PARAMETER	TEST CONDITIONS	MIN	TYP	MAX	UNIT
VIT+ Positive going input threshold voltage	VCC = 2.2V	1.1		1.5	V
	VCC = 3.0V	1.5		1.9	
VIT- Negative going input threshold voltage	VCC = 2.2V	0.4		0.9	V
	VCC = 3.0V	0.9		1.3	
Vhys Input voltage hysteresis (VIT+ VIT-)	VCC = 2.2V	0.3		1.1	V
	VCC = 3.0V	0.5		1.0	

outputs Port 1 to P3; P1.0 to P1.7, P2.0 to P2.5, P3.0 to P3.7

PARAMETER	TEST CONDITIONS			MIN	TYP	MAX	UNIT
V _{OH} High-level output voltage	i _(OHmax) = -1.5 mA	V _{CC} = 2.2 V	See Note 8	V _{CC} -0.25		V _{CC}	V
	i _(OHmax) = -6 mA		See Note 9	V _{CC} -0.6	V _{CC}		
	i _(OHmax) = -1.5 mA	V _{CC} = 3 V	See Note 8	V _{CC} -0.25		V _{CC}	
	i _(OHmax) = -6 mA		See Note 9	V _{CC} -0.6	V _{CC}		
V _{OL} Low-level output voltage	i _(OLmax) = 1.5 mA	V _{CC} = 2.2 V	See Note 8	V _{SS}		V _{SS} +0.25	V
	i _(OLmax) = 6 mA		See Note 9	V _{SS}	V _{SS} +0.6		
	i _(OLmax) = 1.5 mA	V _{CC} = 3 V	See Note 8	V _{SS}		V _{SS} +0.25	
	i _(OLmax) = 6 mA		See Note 9	V _{SS}	V _{SS} +0.6		

- NOTES:
8. The maximum total current, i_{OHmax} and i_{OLmax}, for all outputs combined, should not exceed ±12 mA to hold the maximum voltage drop specified.
 9. The maximum total current, i_{OHmax} and i_{OLmax}, for all outputs combined, should not exceed ±48 mA to hold the maximum voltage drop specified.
 10. One output loaded at a time.

7. PACKAGE DIMENSIONS

7.1. SOP28

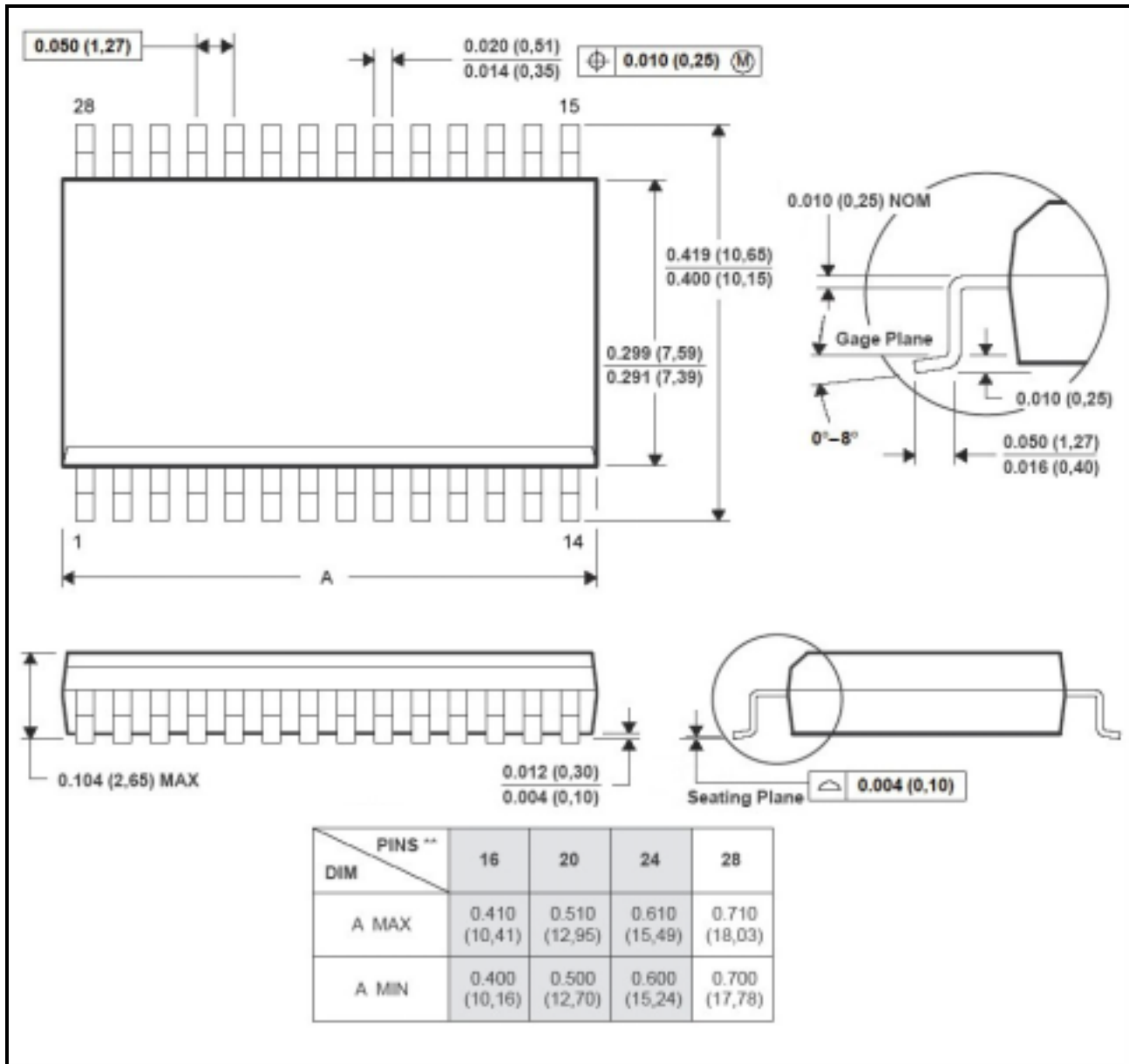

7.2. TSSOP28

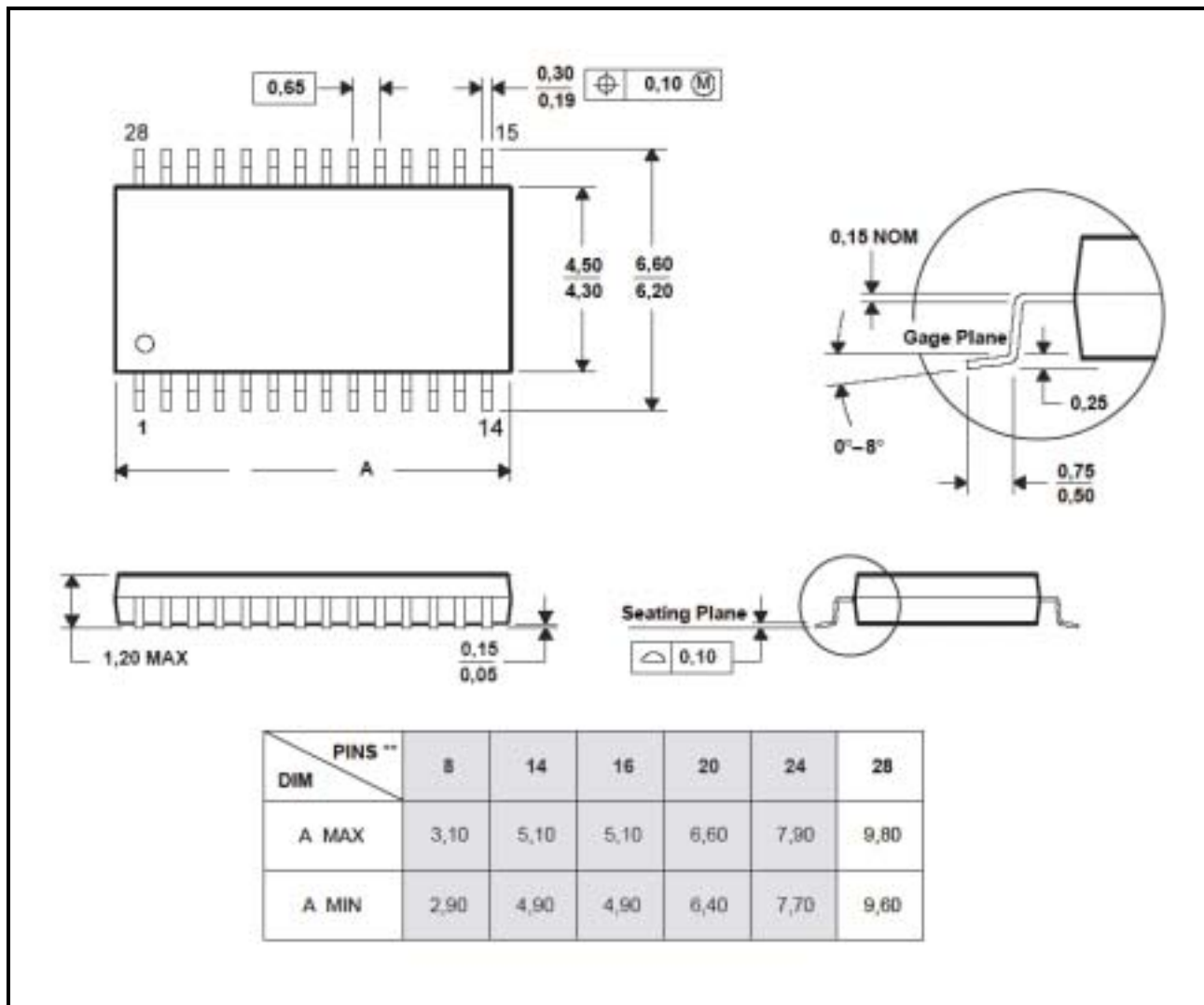

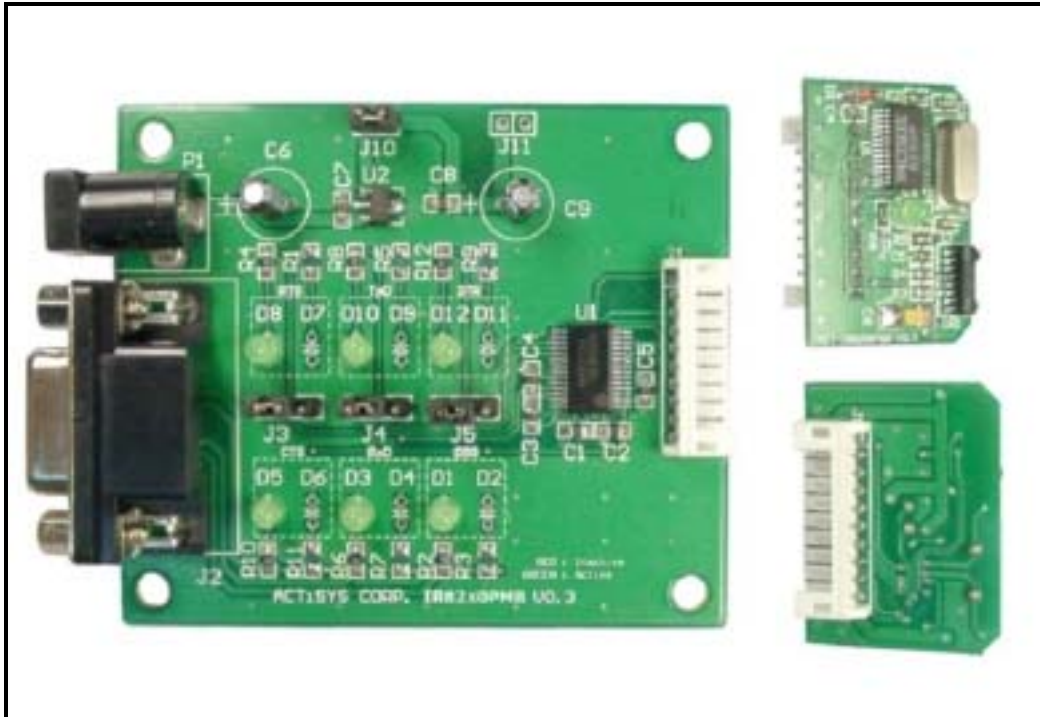
APPENDIX 1. HOW TO USE ACT-IR8250PEK (ACT-IR8250P EVALUATION KIT)

The following steps instruct you how to use ACT-IR8250PEK:

A. ACT-IR8250PEK Package: Includes the following:

- 1) ACT-IR82x0PMB: ACT-IR82x0P IC series to RS232 interface motherboard.
- 2) ACT-IR8250PDB: ACT-IR8250P CMOS 3.3V interface daughter board.
- 3) One 10 pin short cable/connectors to connect ACT-IR8250PDB to ACT-IR82x0PMB.
- 4) One 10 pin connector (J1) to connect ACT-IR8250PDB+cable to your host PCB.
- 5) 5 ~12 VDC AC power adapter.

B. Operating Procedure:

- 1) Connect ACT-IR82x0PMB and ACT-IR8250PDB by using the short 10 pin cable/connectors.
- 2) Plug the DC power in P1 connector. 5V to 12V DC is fine.
- 3) Connect ACT-IR82x0PMB/DB9F directly, or use DB9M-to-DB9F extension cable (straight-through/ none-cross) to PC, or to your embedded host device which has DB9M(DTE) connector. ACT-IR82x0PMB plays as DCE, and any host device to which ACT-IR82x0PMB is attached, is DTE.
- 4) Activate host device's UART port, at this moment, LED D8 and D12 should light up.
- 5) Activate the other IrDA device (e.g. PDA or cellular phone) and face it to ACT-IR8250PDB. If IR link is successfully established between two devices, LED D1 and D5 will light up.

It means you can transmit and receive data between the two IrDA devices now.

- 6) In this IR-link set-up, your embedded host device+ACT-IR82x0PMB is IrDA secondary station, and PDA/cellphone is IrDA primary station. IrDA primary station initiates, commands and establishes IrDA connection.

C. Definition of Jumpers and LEDs:

- 1) LED D8: When it lights up, means DTE (host) enables its RTS. When host UART buffer is going to be full, host should disable this signal line.
- 2) LED D10: When it flashes, means DTE (host) is sending data.
- 3) LED D12: When it lights up, means DTE (host) enables its DTR. Enabling DTR means host is ready and orders ACT-IR8250P to enter ready-to-receive mode.
- 4) LED D1: When it lights up, means ACT-IR8250P enables its DSR. D1 lights off means that IR link is not yet established.
- 5) LED D3: When it flashes, means ACT-IR8250P is receiving data from another IrDA device and sends these data to host device.
- 6) LED D5: When it lights up, means ACT-IR8250P enables its CTS. D5 lights off means ACT-IR8250P is not allowed to receive any data from host device (e.g. buffer full, etc.).
- 7) J3 and J5: If your host just supports 3 wire UART (Tx, Rx, GND), you probably have to set DTR and RTS always enabled, i.e. set ACT-IR8250P in no-flow-control status. To accomplish this, either: a) Pin 2-3 shorted so DTR/RTS are always enabled, or b) Pin 1-2 shorted so host takes control of when DTR/RTS are enabled or disabled.
- 8) J4: Reserved.
- 9) J10: Power jumper, short it to apply external non-regulated power to ACT-IR8250P. You should NOT short J10 if you choose to us J11 below.
- 10) J11: 3VDC regulated power (e.g. battery) input connector traces. You may use this location to place your own 3VDC connector if you don't have available external non-regulated power to connect to J10. J11 MUST NOT be shorted.

D. Please refer to the software "ACT-IR8250SW" user's manual for detail features about ACT-IR8250PEK.

8. WARRANTY INFORMATION

ACTiSYS Corporation warrants the first end-user purchaser, for a period of 1 year from the date of purchase, that this wireless interface (The Product) will be free from defective workmanship and materials, and agrees that it will, at its option, either repair the defect or replace the defective Product or part thereof at no charge to the purchaser for parts or for labor.

This warranty does not apply to any appearance items of the Product, any consumable items such as paper, ink ribbon, or batteries supplied with the Product, or to any equipment or any hardware, software, firmware, or peripheral other than the Product. This warranty does not apply to any Product the exterior of which has been damaged or defected, which has been subjected to misuse, abnormal service or handling, or which has been altered or modified in design, construction or interfacing. Tampering with Label Voids Warranty.

In order to enforce the rights under this limited warranty, the purchaser should mail, ship or carry the Product, together with proof of purchase, to ACTiSYS.

The limited warranty described above is in addition to whatever implied warranties may be granted to purchasers by law. To the extent permitted by applicable law, ALL IMPLIED WARRANTIES INCLUDE THE WARRANTIES OF MERCHANT ABILITY AND FITNESS FOR USER ARE LIMITED TO A PERIOD OF 1 YEAR FROM THE DATE OF PURCHASE. Some states do not allow limitations on how long an implied warranty lasts, so the above limitation may not apply to you.

Neither the sales personnel of the seller nor any other person is authorized to make any warranties other than those described above, or to extend the duration of any warranties beyond the time period described above on behalf of ACTiSYS Corporation.

The warranties described above shall be the sole and exclusive remedy available to the purchaser. Correction of defects, in the manner and for the period of time described above, shall constitute full satisfaction of all claims, whether based on contract, negligence, strict liability or otherwise. In no event shall ACTiSYS Corporation be liable or in any way responsible, for any damages or defects in the Product which were caused by repair or attempted repairs performed by anyone other than ACTiSYS technician. Nor shall ACTiSYS Corporation be liable or in any way responsible for any incidental or consequential economic or property damage. Some states do not allow the exclusion of incidental or consequential damages, so the above exclusion may not apply to you.

FOR YOUR RECORDS

For your assistance in reporting this product in case of loss or theft, please record below the model number and serial, which are located on the bottom of the case. Please retain this information.

Model Number:

Serial Number:

Date of Purchase:



9. CONTACT INFORMATION

GO WIRELESS WITH ACTiSYS IR



ACTiSYS
The Wireless Infra-red Expert

- ◆ IrDA Protocol Software For Portable Devices
- ◆ IrDA Test Software For Hardware Systems
- ◆ IrDA Printer And Computer Adapters

115.2K, 4M and 16M bps

IR100M/1000M

IR2000L

IR220L/L+

The advertisement features a central red graphic with the ACTiSYS logo and tagline. It lists three key offerings: IrDA Protocol Software for Portable Devices, IrDA Test Software for Hardware Systems, and IrDA Printer and Computer Adapters. It also highlights data rates of 115.2K, 4M, and 16M bps. Three specific product models are shown: IR100M/1000M, IR2000L, and IR220L/L+. The graphic is surrounded by images of various devices including a printer, a PDA, a mobile phone, a laptop, a camera, and a scanner, all connected by red lines to the central text.

ACTiSYS Corporation
921 Corporate Way
Fremont, CA 94539, USA
TEL:+1-510-490-8024, FAX:+1-510-623-7268
E-Mail: irda-info@actisys.com
Web: <http://www.actisys.com>